

MJ-SERIES

PULSE METER INSTRUCTIONS

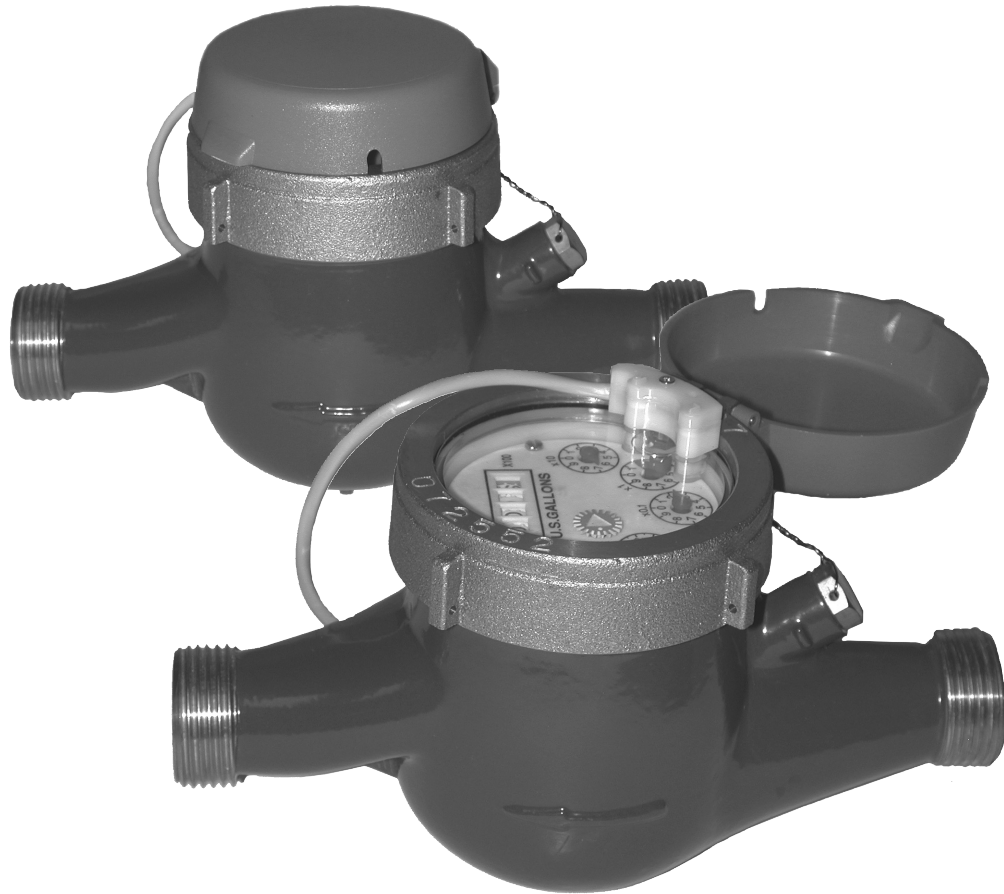

MJ-SERIES PULSE METER INSTRUCTIONS

ISO 9001:2000
CERTIFIED

SeaMetrics

The Leader in Flow Meter Value

GENERAL INFORMATION

MJ-Series meters use the internationally-accepted multi-jet principle. A gear train drives the register totalizer dials. For pulse output, one of the pointers is replaced by a magnet arm, which is detected by an encapsulated sensor attached to the outside of the lens.

MJE meters use a solid-state, long-lasting Hall-effect sensor, which requires power. They are suited for use with SeaMetrics controls and metering pumps (LMI for instance) that have sensor power.

MJR meters use a reed switch. They provide a dry contact closure and do not require power.

MJT meters do not have a sensor, and they totalize only.

SPECIFICATIONS

Power	6 mA at 12 Vdc (MJE only)			
Temperature	105° F (40° C) max			
Pressure	150 psi operating			
Materials Body	Cast bronze			
Internals	Engineered thermoplastic			
Magnet	Alnico			
Accuracy	+/- 1.5% of reading			
	MJE	MJR	MJT	
Sensor	Hall-effect	Reed switch	Totalizer only	
Maximum Current	20 mA	20 mA	n/a	
Maximum Voltage	24 Vdc	24 Vdc or Vac	n/a	
Cable Length	12' (4 m) standard (2000' maximum run)			
Flow Rates (GPM)	3/4"	1"	1-1/2"	2"
Minimum	0.22	0.44	0.88	1.98
*Maximum	22	52	88	132

***CAUTION:** Excessive flow can cause breakage. Do not exceed recommended maximums.

INSTALLATION

Position. MJ-Series meters should be installed horizontally with the register up. Vertical mounting will result in some degree of under-measurement and shortened life of the bearings. No upstream straight pipe is required.



These water meters are not recommended for installation indoors or anywhere leakage may cause damage.

Couplings. Male NPT threaded couplings are included with each meter. The threads on the end of the meter are IPS straight threads one size bigger than the meter size. Though it is possible to thread a standard pipe coupling directly onto the meter for close coupling, the included couplings are much preferable because they provide a union connection for meter service. Be sure to use the included gasket between the end of the meter and the coupling.

Connections. MJE and MJR sensors are supplied with a color coded output cable (see diagram, page 3). Optional connectors can be ordered to plug directly into a SeaMetrics control or metering pump.

Pulse Output. Both MJE and MJR sensors respond to a magnet that rotates on the face of the meter under the lens. The sensor turns on and off once each time the magnet passes under it. Sensors are designed for electronic control loads, and should not be used to switch power loads or line voltages. See maximum current and voltage ratings, under Specifications.

MAINTENANCE

SeaMetrics recommends all service to be performed by an authorized distributor or the factory to maintain the integrity of the protective tamper-proof wire-and-seal.

Inlet Strainer. Clean the strainer yearly, or as required, depending on water condition. Pull out the strainer or back-flush the meter to loosen trapped particulates.

Calibration. Meters used for billing or billing exemption may be regulated by state or local authorities. New meters are factory-tested to meet the AWWA C-708 Multi-Jet Meter accuracy specification. Some states require retesting at various intervals, typically eight years for 3/4" meters, six for 1", and four for 1-1/2" and 2". Meters used for control should be tested every 5-10 years. Testing can be done by the factory or local meter shops authorized for this purpose. *Please contact SeaMetrics before sending meter in for calibration or servicing.*

Changing Pulse Rates: See Page 3.

Internal Parts Replacement: See Page 4.

CHANGING PULSE RATES

The pulse rate is determined by the dial on which the magnet pointer is located. To move the magnet pointer, remove meter top and lens, taking care not to lose the sealing ring. With fingers, lift the magnet pointer off its shaft and remove the plain pointer from the target dial. Reverse their positions and press them firmly into place. Securely seat the sealing ring and then replace the lens, matching the tab on the lens to the notch on the meter so as to align the sensor with the magnetic pointer dial. Thread the meter top on and tighten.

	Pulse Rate	Drive Gear Position	Connection Diagram #
3/4"	*20 P/G	factory order	2
	10 P/G	factory order	1
	*2 P/G	X0.1	2
	1 P/G	X0.1	1
	*5 G/P	X1	2
	10 G/P	X1	1
	*50 G/P	X10	2
	100 G/P	X10	1
1"	*2 P/G	X0.1	2
	1 P/G	X0.1	1
	*5 G/P	X1	2
	10 G/P	X1	1
	*50 G/P	X10	2
1-1/2"	*2 P/G	X0.1	2
	1 P/G	X0.1	1
	*5 G/P	X1	2
	10 G/P	X1	1
	*50 G/P	X10	2
2"	*2 P/G	X0.1	2
	1 P/G	X0.1	1
	*5 G/P	X1	2
	10 G/P	X1	1
	*50 G/P	X10	2
*These pulse rates available in MJR (reed switch) meters only.			

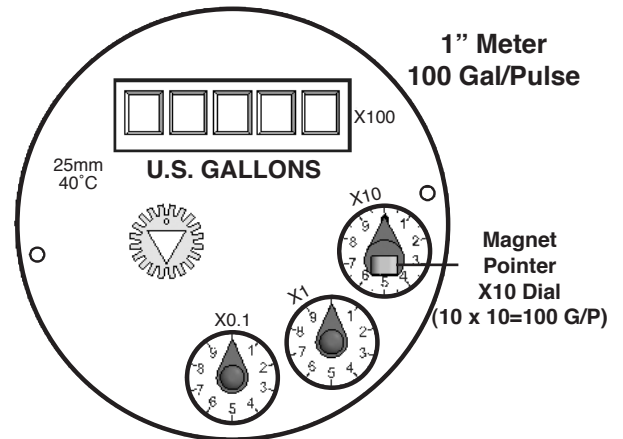
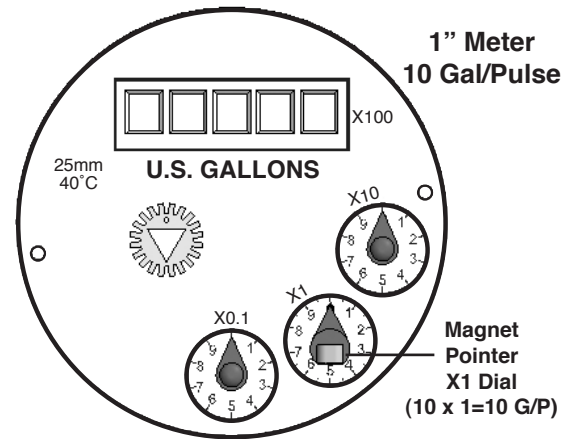
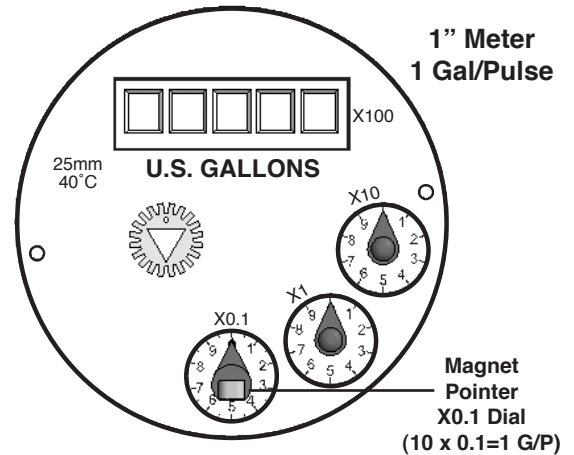

CONNECTION DIAGRAMS

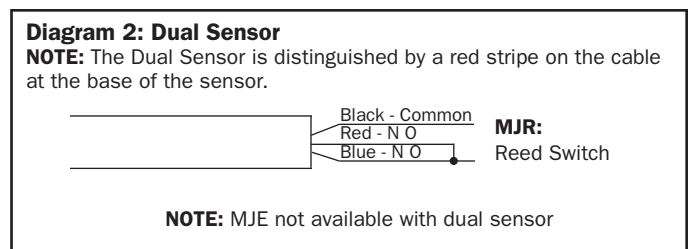
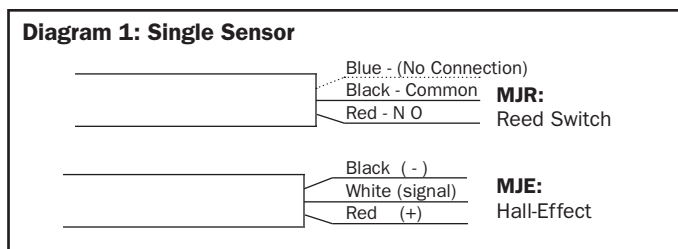

MAINTENANCE and REPAIR

Internal Parts Replacement. All of the internal parts of an MJ-Series meter lift out as a unit, after the top has been unscrewed. The lens can then be removed and the internal

assembly lifted out. If necessary, turn the meter upside down and tap one end lightly on a countertop to loosen the internals. The assembly can be separated by hand.

MJ-SERIES PARTS

MJ-SERIES		3/4"	1"
1		Lid and Hinge Pin Assembly	31616 31617
2		Lens Gasket Assembly	31619 31620
3	a	Internal Assembly (gallons)	31621 31622
	b	Internal Assembly (cubic feet)	31625 31626
4		Coupling Assembly (incl 2 sets)	31484 31485
5		Coupling Gasket Assembly (incl 2)	31629 31630
6		Lens	31471 31471
7		Sensor Screw	31519 31519
8	a	Single Reed Switch Sensor (MJR)	31444 31444
	b	Double Reed Switch Sensor (MJR)	31457 31457
	c	Single Hall-Effect Sensor (MJE)	31612 31612
9	a	Register (gallons)	31463 31464
	b	Register (cubic feet)	31473 31474
10		Internal Strainer	31483 31517
11		Tubular Strainer	31496 31497

MJ-SERIES		1 1/2"	2"
1		Lid and Hinge Pin Assembly	31618 31618
2		Lens Gasket Assembly	31633 31633
3	a	Internal Assembly (gallons)	31623 31624
	b	Internal Assembly (cubic feet)	31627 31628
4		Coupling Assembly (incl 2 sets)	31486 31487
5		Coupling Gasket Assembly (incl 2)	31631 31632
6		Lens	31471 31471
7		Sensor Screw	31519 31519
8	a	Single Reed Switch Sensor (MJR)	31444 31444
	b	Double Reed Switch Sensor (MJR)	31457 31457
	c	Single Hall-Effect Sensor (MJE)	31612 31612
9	a	Register (gallons)	31465 31466
	b	Register (cubic feet)	31475 31476
10		Internal Strainer	31518 31518
11		Tubular Strainer	31498 31499

Except as noted, individual parts are not available.

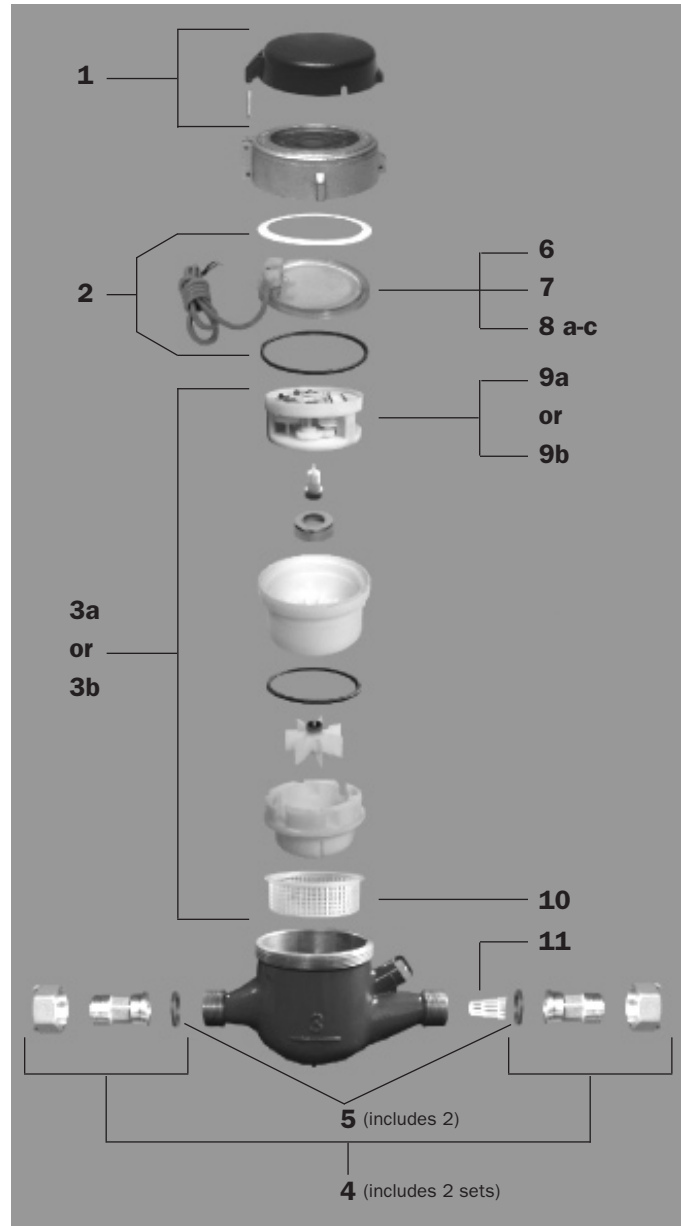

SeaMetrics Incorporated • 19026 72nd Avenue South • Kent, Washington 98032 • USA
 (P) 253.872.0284 • (F) 253.872.0285 • 1.800.975.8153 • www.seametrics.com