



FEATURES

- Rugged ABS plastic housing
- Optoisolated Transistor and relay outputs

APPLICATIONS

- Cooling tower/boiler water treatment
- Pacing chemical metering pumps
- Driving multiple pumps, counter timers, remote totalizers

GENERAL INFORMATION

The PS40 is a low-voltage device that allows a SeaMetrics flow sensor to drive multiple (up to four) pulse-responsive devices, such as solenoid-driven chemical metering pumps, counter timers, or remote totalizers. It requires an external DC power supply for operation and can provide power to a single low power SeaMetrics flow sensor, such as an MJE meter. It can also be used with a dry contact sensor, such as the MJR reed switch meter.

DIMENSIONS

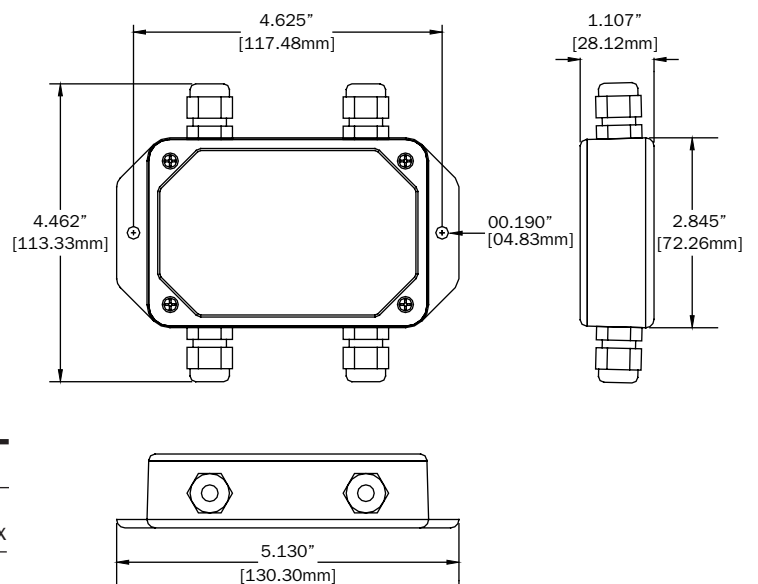

SPECIFICATIONS*

| | |
|----------------------|--|
| Power | 10 - 36 Vdc |
| Relay | Operational frequency = 50 Hz max Contacts = 250 mA max, 36 Vdc max, 3W max |
| Optoisolation | 10 mA max @ 30 Vdc max |
| Outputs | Three open collector optoisolated One Form C relay |

*Specifications subject to change • Please consult our website for current data (www.seametrics.com).

Connections. Remove the PS40 cover to access the terminals. Follow the Connections diagram. Use the included nuts to secure the strain reliefs on the inside of the enclosure before connecting to the terminals.

Power. A DC power supply of 10 to 36 Vdc is required. Connect the +V and -V terminals to the DC + and - as shown.

Sensor. If using a two-wire (e.g., MJR meter), note which two of the three terminals are to be used. Either of the sensor wires can be connected to either of these two terminals. Three-wire sensors (e.g., MJE meters) are polarity-sensitive and must be connected to the appropriate terminals by standard SeaMetrics color code: red is +, black is -, and white is Signal.

Output. Three of the outputs are transistor, the fourth is relay. The transistor outputs will operate almost all pulse-responsive metering pumps and all SeaMetrics controls,

provided that the polarity is correct. The relay output is identified by its terminals marked NO (normally open), COM (common), and NC (normally closed). The relay output will operate essentially everything, including the very rare pump or control that will only work with dry contact.



Caution: The relay output is designed for electronic controls only. Maximum current load is 250 mA.

High Speed Input. It may be occasionally desirable to use the PS40 with a high-speed input, such as an IP80 paddle-wheel flow sensor. If the sensor will be putting out more than 50 pulses per second, it is necessary to disable the relay output, which cannot operate at such high speeds. To do this, clip the jumper marked JP1 (see diagram). Note that the relay output terminals cannot be used in this case.

CONNECTIONS

